



NOISE & VIBRATION INDUSTRIAL HYGIENE SOLUTIONS

NOISE DOSIMETERS, HUMAN VIBRATION METERS, AND
SOUND LEVEL METERS

 **LARSON DAVIS**
A PCB DIVISION

larsondavis.com | 1 716 926 8243

INDUSTRIAL NOISE ASSESSMENT

Industrial Hygienists and safety professionals responsible for protecting workers from dangerous levels of noise in the workplace often need to map sound levels in key parts of an industrial environment or throughout an entire plant. Sound maps – (often called sound surveys, noise surveys, or occupational noise surveys) – give health and safety professionals important information to begin the process of reducing worker noise exposure.

Task-based or job-based noise measurements are another component of industrial acoustics – the noise to which a worker is exposed in a given task is measured, and then a formula is used to calculate the overall noise exposure for the workday. An accurate, easy-to-use, IEC and ANSI compliant sound level meter is key to compiling useful sound level information. Octave bands provide information that can help identify noise source and select appropriate hearing protection.



SPARTAN™ SOUND LEVEL METER

SERIES 821

Spartan Sound Level Meter is an ideal tool for workplace noise exposure assessment and plant noise surveys. Fully compliant with IEC and ANSI standards for Class 1 or Class 2 sound level meters, Spartan supports ISO 9612:2009 measurement strategies for task or job-based measurements. Included software offers data visualization and streamlined results reporting.

- Large, responsive touch display
- Long battery life – up to 40 hours
- Built-in dosimetry tools
- Automatic data download via Bluetooth or USB options
- Flexible powering options, including wireless charging
- Optional 1/1 and 1/3 octave band analysis available
- Ready to measure in seconds with quick boot time
- Included software offers data analysis and reporting



PERSONAL NOISE EXPOSURE

Industrial Hygienists, EHS Consultants, and Safety Managers know that complying with noise exposure limits protects workers from permanent noise-induced hearing loss. Understanding actual noise levels experienced by individuals in the workplace is key to complying with guidelines established by OSHA, ISO, and other global directives. One way to determine whether an individual's noise exposure is within acceptable limits is to measure personal noise exposure with a noise dosimeter that meets IEC and ANSI noise dosimetry standards and provides exposure levels in an easy-to-understand format. Knowledge of a worker's daily noise exposure is critical information in mitigation of worker hearing loss risk, deployment of hearing conservation programs and engineering noise controls.



SPARTAN™ NOISE DOSIMETER

MODEL 730

With Spartan, control test setup, timers, and measurements for up to four virtual dosimeters on a single device wirelessly via the easy-to-read display and on-device navigation. For greater efficiency, perform these tasks wirelessly via low-energy Bluetooth from a PC or via the exclusive mobile app, LD Atlas™. Spartan facilitates faster, simpler, consistent operation designed to save time and money.

With LD Atlas, all essential tasks, including viewing real-time exposure data, exceedances, battery life, and measurement metrics, can be completed directly from your iOS® or Android® device. Monitor devices free from the worry of interfering with the work routine of the person being measured. Generate reports, including the full data file, from the mobile interface before sharing via email. Spartan Noise Dosimeters are configured with built-in wireless charging pads in a robust travel case and available in 1-, 3-, 5-, and 10-packs.

- Full control and live monitoring via LD Atlas app
- Programmable (on/off) LED alarm for exceedances or actions
- Built-in bump detection and motion detection
- Voice-to-text notations with LD Atlas app
- Optional Event Sound Recording (730-ESR)
- Optional 1/1 Octave Band filters (730-OB1)
- Optional Bluetooth disabling (730-NBT)



SPARTAN™ INTRINSICALLY SAFE NOISE DOSIMETER

MODEL 730IS

- All of the benefits of Spartan in an intrinsically safe design
- ATEX, MSHA, UL 913, IECEx, FCC, UKCA, CAN/CSA C22.2, ANZEx approved

SPARTAN-IS SAFETY RATINGS/MARKINGS:

	ATEX/IECEx/UKCA/ANZEx	ITS20ATEX205538X
	II 1G Ex ia IIC T165 °C Ga I 1M Ex ia I Ma IECEx ETL 19.0045X	ITS21UKEX0463X ANZEx 23.3001X -10 °C ≤ TAMB ≤ +50 °C

	CAN/USA	Groups A, B, C & D,
	Class I, Zone 0, AEx ia IIC T165 °C Ga Class I, Division 1,	T165 °C -10 °C ≤ TAMB ≤ +50 °C

APPROVAL NO. 18-A210001-0

PERSONAL VIBRATION EXPOSURE

Excessive exposure to vibration, whether through the whole body or confined to the hand and arm, has wide-ranging, harmful effects. For Industrial Hygienists, measuring a worker's exposure to vibration is key to avoiding vibration-related injury and illness. If measured vibration values are higher than action values specified in national and international standards, workers may be at a significant risk of injury. Low back and neck pain, vestibular issues, and hand-arm vibration syndrome are all serious consequences of human body vibration exposure. Human vibration measurement tools with built-in metrics linked to standards assist safety professionals in understanding risk and making smart decisions about exposure risks and actions or deployment of administrative or engineering controls.



HUMAN VIBRATION METER

MODEL HVM200

The HVM200 is a small, rugged, 3 channel human vibration meter with built-in Wi-Fi, designed to measure hand-arm, whole body, and general vibration. It includes the metrics and frequency weightings needed to measure human vibration. The measurement filters meet the requirements of ISO 8041:2017 and are designed to measure per ISO 2631-1, -2, & -5 and ISO 5349 in support of the American Conference of Governmental Industrial Hygienists (ACGIH) Threshold Limit Values (TLVs), Vibration at Work Regulations 2005, and the directive 2002/44/EC. This makes the HVM200 an ideal choice to demonstrate compliance with human vibration requirements and regulations worldwide.

- Designed for hand-arm, whole body, and general vibration measurements
- Control and view data from LD Atlas mobile app
- Meets ISO criteria and EU directives
- Ergonomically designed mounting adaptors and application optimized ICP® accelerometers
- USB 2.0 and Wi-Fi
- Removable Micro SD Memory Card
- Replaceable Lithium Battery



LD ATLAS™ MOBILE APP

FOR SPARTAN & HVM200

Install LD Atlas on your phone or tablet – available for both iOS and Android – and connect to your Spartan Sound Level Meter Series 821, Spartan Noise Dosimeter Series 730 and Human Vibration Meter Model HVM200. Use LD Atlas to easily check on the status of your meter, make setup changes for a new measurement, analyze data, listen to recorded audio files, and even create and share PDF reports.



SPECIFICATIONS

SPARTAN™ SOUND LEVEL METER

SPECIFICATIONS				
Model	721 IH	721 IH-D	821 IH	821 IH-D
Class	2	2	1	1
Time History Logging	✓	✓	✓	✓
Measurement History	✓	✓	✓	✓
Dosimetry	✓	✓	✓	✓
OBA (1/1 and 1/3 Bands)	-	✓	-	✓
Dynamic Range (A-weighted typical)	16 to 140 dB			
Time Weightings	Fast, Slow & Impulse			
Frequency Weightings	A, C & Z			
Data Storage (microSD card)	8 GB standard Up to 32 GB (μSDHC) and 256 (μSDXC)			
Communication	USB-C, Bluetooth BLE 4.1			
Display	480 x 800 color with capacitive touch			
Power	Internal Lithium battery, USB-C or external 12 V			
Battery Recharge	Qi Wireless, USB-C, or external 12 V			
Runtime (internal battery @ 22 C)	40 hours (display off) 15 hours (display on)			
External Power	6 V to 24 V DC (600 mW w/display off)			
Logging	Time history: 1 s to 1 h Measurement History: 1 min to 6 h			
Metrics	Leq, Lmax, Lmin, Lpeak, Ln (6 values), Time above			
1/1 and 1/3 Octave Metrics (Optional)	Leq, Lmax, Lmin			
Signal Output	AC/DC on 3.5 mm TRS jack			
Preamplifier	Removable PRM821			
Operating Temperature	-30 to 60 °C			
Dimensions (H x W x D)	10.1 x 3.3 x 1.3 inches 260 x 83 x 32 mm			
Weight	12.1 oz (383 g)			
Filters (Optional)				
Bandwidth	1/1 and 1/3 Octaves			
Frequencies (base 10)	1/1: 8 Hz to 16 kHz 1/3: 6.3 Hz to 20 kHz			
Standards Compliance	ANSI S1.11-2014 Class 1 IEC 61260:2014 Class 1			
Standards				
Acoustic	ANSI S1.4-2014 Class 1 IEC 61672-1:2013 Class 1			
Noise Dosimetry	ANSI S1.25-1991 IEC 61252:2017			
Safety	Directive 2014/35/EU IEC 61010-1:2010 RoHS Directive 2011/65/EU			
Approvals	CE, RoHS, WEEE			

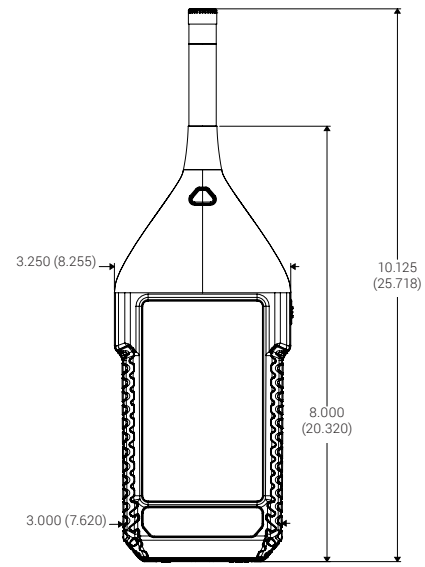

Outline Drawing - Front

Dimensions in inches (centimeters).



Meter Ports

SPARTAN NOISE DOSIMETER MODEL 730 AND INTRINSICALLY SAFE MODEL 730IS

SPECIFICATIONS	
Performance	
Standards	ANSI S1.25-1991 (R2017), IEC 61252 Ed. 1.2
Linear Operating Range	52 – 140 dB rms A-weighted
Dynamic Range	94 dB
Peak Range	78 – 143 dB Peak, C-weighted
Peak Weightings	A, C, Z
RMS Weightings	A, C, Z
Time Weightings	Slow, Fast, Impulse
Frequency Range	20 Hz to 10 kHz
Data Logging	Selectable 1 second or 1 minute samples
Logged data	L_{Aeq} , L_{Ceq} , L_{Cpeak} , L_{Zpeak} , L_{ASmax} , L_{AFmax} , TWA3, TWA5, Motion
Memory	730: 32 GB internal; 730IS: 2 GB internal
Communications	Bluetooth Low Energy 4.1 USB 2.0 (Micro-B connector)
Battery	730: Rechargeable Lithium Ion; 730IS: Rechargeable NiMH
Run Time	730: 40 hours typical; 730IS: 30 hours typical
Charge Time	730: 3 hours from full discharge; 730IS: 16 hours from full discharge
Charger	Qi-compliant wireless or USB
Compliance	CE, ROHS, WEEE
Motion	Overall motion percentage and bump
Languages	English, Spanish, Italian, French, Portuguese, German
Virtual Dosimeter	
Virtual Dosimeters	4 independent with configurable LED indication
Exchange Rate	3, 4, 5, 6
Criterion Level	70.0 to 100.0 dB
Threshold	70.0 to 100.0 dB
Shift Time	1 to 24 hours
Alarms	2 independent with configurable indication
Measurement Results	Dose; ProjDose; L_{AVG} ; TWA(8); Proj TWA(8); Lex,8h; Lep,d; Proj Lep,d
Summary Measured Values (Common to all virtual dosimeters)	
$L_{\omega T}$ (SPL), $L_{\omega eq}$ (Leq), $L_{\omega pk}$ (Lpeak), $L_{\omega TMax}$ (Lmax), $L_{\omega TMin}$ (Lmin) where $\omega = A, C, \text{ or } Z$ frequency weighting T = F, S, or I time weighting Lpeak, Lmax, & Lmin including time of occurrence L_{C-A} , Exposure (Pa^2s & Pa^2h), Motion Exceedance count and time for 2 rms and 3 peak thresholds Overload count, duration, and percentage	
Mechanical	
Display	Color LCD 176 x 176 pixels, always on with low light sensor and front light
Keys	Four buttons
Weight (including clips and windscreen)	730: 112 g (4.2 oz.); 730IS: 130 g (4.6 oz.)
Dimensions	85 x 54 x 39 mm (3.35 x 2.13 x 1.54 in.) dosimeter only

SPECIFICATIONS (CONTINUED)																										
Microphone	¼-inch Model 375A03																									
Operating Temperature	-10 to +50 °C (14 to 122 °F)																									
Operating Humidity	Up to 90% RH, non-condensing																									
1/1 Octave Filters (optional)																										
Standards	ANSI/ASA S1.11-2014; IEC 61260-1:2014 Class 1																									
Filters	31.5 Hz to 8 kHz																									
Linear Operating Range	42 to 140 dB @ 1 kHz																									
Measured Results	L_{Zeq} (Leq), L_{ZTMax} (Lmax), L_{ZTMin} (Lmin)																									
Event Audio Recording (optional)																										
Format	16-bit .wav																									
Sample Rate	8 kHz																									
Recording Time	Fixed: 2 s pre-trigger and 10 s post-trigger																									
Trigger Source	L_{AS} , L_{AF} , L_{CS} , L_{CF} , $L_{Aeq,1s}$, $L_{Ceq,1s}$																									
Trigger Level	40 – 140 dB, selectable																									
ORDERING INFORMATION																										
730	Spartan 730 noise dosimeter with one windscreen and two clips. Includes calibration certificate																									
730IS	Spartan 730IS intrinsically safe noise dosimeter with one windscreen and two clips. Includes calibration certificate																									
730-PKxx-EU* 730-PKxx-UK* 730-PKxx-US*	Complete Spartan 730 noise dosimeter kit that includes quantity 'xx' dosimeters. Each dosimeter includes one windscreen, two clips, and a calibration certificate.**																									
	<table border="1"> <thead> <tr> <th>'xx'</th> <th>Spartan 730 Dosimeters</th> <th>Calibrator (qty 1)</th> <th>Calibration Adapter</th> <th>Case</th> </tr> </thead> <tbody> <tr> <td>01</td> <td>1</td> <td>CAL1150</td> <td>1 x ADP109</td> <td>CCS056</td> </tr> <tr> <td>03</td> <td>3</td> <td>CAL1150</td> <td>2 x ADP109</td> <td>CCS057</td> </tr> <tr> <td>05</td> <td>5</td> <td>CAL1150</td> <td>2 x ADP109</td> <td>CCS058</td> </tr> <tr> <td>10</td> <td>10</td> <td>CAL1150</td> <td>2 x ADP109</td> <td>CCS059</td> </tr> </tbody> </table>	'xx'	Spartan 730 Dosimeters	Calibrator (qty 1)	Calibration Adapter	Case	01	1	CAL1150	1 x ADP109	CCS056	03	3	CAL1150	2 x ADP109	CCS057	05	5	CAL1150	2 x ADP109	CCS058	10	10	CAL1150	2 x ADP109	CCS059
	'xx'	Spartan 730 Dosimeters	Calibrator (qty 1)	Calibration Adapter	Case																					
	01	1	CAL1150	1 x ADP109	CCS056																					
	03	3	CAL1150	2 x ADP109	CCS057																					
05	5	CAL1150	2 x ADP109	CCS058																						
10	10	CAL1150	2 x ADP109	CCS059																						
<ul style="list-style-type: none"> - EU includes a Type C power plug for use in Europe - UK includes a Type G power plug for use in the UK - US includes a Type A power plug for use in North America 																										
730-ESR	Option to add event sound recording																									
730-OB1	Option to add 1/1 octave filters																									
730-NBT	Option to disable Bluetooth																									
Accessories																										
CAL150	Class 2 calibrator, with user-selectable output 94 or 114 dB at 1 kHz, ½ in. opening with ¼ in. adaptor (ADP109) and calibration certificate included																									
WS012-XX	Replacement windscreen for Spartan 730. Available in 1, 3, 5, 10, or 25 packs where XX is the number of windscreens																									
730-CLIPS	Replacement clip, quantity 2																									
CER-730	ISO 17025 factory calibration and certification of Spartan																									
CER-730-OBA	Calibration of 1/1 octave filters																									
ADP109	Calibrator adaptor for ½ in. to ¼ in. opening. Used with Spartan																									

*730IS intrinsically safe version is available for these models (replace "730" with "730IS")

**Versions without CAL1150 calibrator available

HUMAN VIBRATION METER MODEL HVM200

GENERAL SPECIFICATIONS	
Input	
Input	ICP®, IEPE or CCP
Excitation Current	2 mA
Input Connector	¼-28 4-pin male
Input Linear Range	
Fc weighting	0.2 mV to 5.0 V at 80 Hz
Wh weighting	0.9 mV to 5.0 V at 16 Hz
Bandwidth	0.4 Hz to 3000 Hz
Range	Single range
Calibration	TEDS or manual entry
Sample Rate	7161.458 Hz
Measured Values	
Measurement Modes	Hand-arm, Whole-body, Vibration
Metrics by mode	
Vibration	RMS, Peak, Min, Max (x, y, z, & Σ)
Hand-arm	RMS, Peak, Min, MTVV, A(1), A(2), A(4), A(8) (x, y, z & Σ)
Whole-body	RMS, Peak, Min, MTVV, A(8), A(8)Exp, EP, VDV (x, y, z & Σ)
Frequency Weightings	
Vibration	Fa (0.4 Hz to 100 Hz), Fb (0.4 Hz to 1250 Hz), Fc (6.3 Hz to 1250 Hz)
Hand-arm	Wh
Whole-body	Wb, Wc, Wd, We, Wf, Wj, Wk, Wm
Measurement Units	m/s ² , cm/s ² , ft/s ² , in/s ² , g, dB
Time History (Logging)	
Store Interval	1, 2, 5, 10, 20, 30 s; 1, 2, 5, 10, 20, 30 min; 1hr
Stored Values	RMS and peak for x, y, z & Σ
1/1 and 1/3 Octave Filters (Optional)	
1/1 Octave Filters	0.5 Hz to 2000 Hz
1/3 Octave Filters	0.4 Hz to 2500 Hz
Weighting	Unweighted
Measured Values	RMS, Max
Compliance	IEC 61260-1:2014 Class 1
	ANSI S1.11-2014 Part 1, Class 1
Power Supply	
Internal Battery	Rechargeable Li-ion, user replaceable
External power	USB (PSA035)
Charge Time	3.5 hours using PSA035
Battery Run Time	Up to 9 hours (12 hours for WiFi disabled or disconnected)
Communication	USB-B, Wi-Fi 802.11 b/g/n
Physical	
Dimensions (H x W x D)	4.6 x 2.6 x 0.7 inches 118 x 67 x 18 mm
Weight (including battery)	4.6 oz. (130 gm)
Environmental	
Operating Temperature	14 °F to 122 °F (-10 °C to 50 °C)
Operating Humidity	0 to 90% relative humidity, non-condensing

GENERAL SPECIFICATIONS (CONTINUED)	
Included Accessories	
PSA035	100 – 240 VAC to 5V USB power supply with adapters
BAT018	Internal rechargeable lithium battery
Compliance	
ISO 8041:2017 Human response to vibration - Measuring Instrumentation (See manual for scope of compliance)	
IEC 61010-1 (2010) Safety	
IEC 61326-1:2013 EMC	
IEC 61325-2-3:2013 EMC safety	
ISO 2631-1:1997 Whole-body vibration – General requirements	
ISO 2631-2:2003 Whole-body vibration –Vibration in buildings	
ISO 2631-4:2001 Whole-body vibration – Rotational motion	
ISO 5349-1:2001 Hand-transmitted vibration – General requirements	
ISO 5349-2:2001 Hand-transmitted vibration – Practical guidance	
EN 1032:2003 Mechanical vibration - Testing of mobile machinery	
ANSI S2.70	
ORDERING INFORMATION	
HVM200	3-channel vibration meter for general and human vibration. Includes CBL217-01. Sensors not included
HVM200-HA-40F	Kit for hand-arm vibration includes HVM200, CCS047, CCS048-L, ADP081A, SEN040F & SWW-G4-HVM
HVM200-WB	Kit for whole body vibration includes HVM200, CCS047, SEN027 & SWW-G4-HVM
HVM200-ALL-40F	Kit for hand-arm and whole body vibration includes HVM200, CCS047, CCS048-L, ADP081A, SEN040F, SEN027 & SWW-G4- HVM
HVM200-0B3	Option for 1/1 and 1/3 octave filters. Includes SWW-G4-HVM
HVM200-RAW	Option to record sampled waveforms for all three channels
SWW-G4-SDK	Software Development Kit
Optional Accessories	
CBL216	¼-28 4-pin to 4-pin mini connector for SEN026
CBL217	¼-28 4-pin to ¼-28 4-pin, 5 ft. (1.5 m) cable
SEN020	Triaxial accelerometer, 0.1 mV/(m/s ²), 10-32 fem thread
SEN026	Triaxial accelerometer, 1 mV/(m/s ²), for ADP063
SEN027	Seat pad with triaxial accelerometer, 10 mV/(m/s ²)
SEN040F	Triaxial accelerometer, 0.1 mV/(m/s ²), for ADP080A, 81A and 82A
SEN041F	Triaxial accelerometer, 1 mV/(m/s ²), for ADP080A, 81A and 82A
ADP063	Palm adapter for use with SEN026
ADP080A	“T” adapter for use with SEN040F or SEN041F
ADP081A	Handle adapter for use with SEN040F or SEN041F
ADP082A	Circle clamp adapter for use with SEN040F or SEN041F
ADP084A	Kit including ADP080A, ADP081A, ADP082A and ADP063
CCS047	Hard shell case for HVM200 and accessories
CCS048-S	Small arm band for HVM200, fits arm circumference of 8 to 12.5 in. (20 to 32 cm)
CCS048-L	Large arm band for HVM200, fits arm circumference of 10.5 to 16.5 in. (27 to 42 cm)
394C06	Hand-held shaker, 9.81 m/s ² at 159.2 Hz
CER-HVM200	Factory calibration of HVM200, does not include sensor



3425 Walden Avenue, Depew, NY 14043 USA

larsondavis.com | sales@larsondavis.com | 888 258 3222 | +1 716 926 8243

© 2026 PCB Piezotronics, Inc. - all rights reserved. In the interest of constant product improvement, specifications are subject to change without notice. PCB Piezotronics, Inc. is a wholly-owned subsidiary of Amphenol Corporation. Accumetrics, Inc., PCB Piezotronics of North Carolina, Inc. and The Modal Shop, Inc. are wholly-owned subsidiaries of PCB Piezotronics, Inc. IMI Sensors, Endevo and Larson Davis are Divisions of PCB Piezotronics, Inc. Except for any third party marks for which attribution is provided herein, the company names and product names used in this document may be the registered trademarks or unregistered trademarks of PCB Piezotronics, Inc. or its subsidiaries. Detailed trademark ownership information is available at www.pcb.com/trademarkownership.

MD-0390-rev0 0326