

# CAL291

## Residual Intensity Calibrator



## Reference Manual



Larson Davis Inc.  
1681 West 820 North  
Provo, UT 84601-1341  
Phone: (801) 375-0177  
FAX: (801) 375-0182  
[www.larsondavis.com](http://www.larsondavis.com)  
I291.01 Rev A

## **Copyright**

Copyright 2005 by Larson Davis, Incorporated. This manual is copyrighted, with all rights reserved. The manual may not be copied in whole or in part for any use without prior written consent of Larson Davis, Inc.

## **Disclaimer**

The following paragraph does not apply in any state or country where such statements are not agreeable with local law:

Even though Larson Davis, Inc. has reviewed its documentation, Larson Davis Incorporated makes no warranty or representation, either expressed or implied, with respect to this product and documentation, its quality, performance, merchantability, or fitness for a particular purpose. This documentation is subject to change without notice, and should not be construed as a commitment or representation by Larson Davis, Inc.

This publication may contain inaccuracies or typographical errors. Larson Davis, Inc. will periodically update the material for inclusion in new editions. Changes and improvements to the information described in this manual may be made at any time.

## **Equal Opportunity Employer**

Larson Davis is an equal opportunity employer and does not discriminate on the basis of race, color, religion, gender, national origin, disability or veteran status.

## **Customer Service**

In the U.S. call toll-free: 888-258-3222

International customers call: 801-375-0175

FAX: 802-375-0182

Worldwide Web: [www.LarsonDavis.com](http://www.LarsonDavis.com)

## **Record of Serial Number and Purchase Date**

Please examine your instrument and record the following information below. You may be asked to give this information in any future communications you have with Larson Davis, Inc.

CAL291 # \_\_\_\_\_

Date of Purchase: \_\_\_\_\_

## **Recycling**

Larson Davis, Inc. is an environmentally friendly organization and encourages our customers to be environmentally conscious. When this product reaches its end of life, please recycle the product through a local recycling center or return the product to:

**Larson Davis, Inc.**

**Attn: Recycling Coordinator**

**1681 West 820 North**

**Provo, Utah, USA 84601**

where it will be accepted for disposal



# Table of Contents

<b>Chapter 1</b>	<b>Introduction</b>	<b>1-1</b>
	About This Manual .....	1-1
	Features .....	1-1
	Applications .....	1-2
	Unpacking and Inspection .....	1-3
	Accessories and Optional Equipment .....	1-3
<b>Chapter 2</b>	<b>Description</b>	<b>2-1</b>
	General Description .....	2-1
	Microphone Openings .....	2-2
	End Plate .....	2-3
	Connectors .....	2-3
	Input .....	2-3
	Power .....	2-3
<b>Chapter 3</b>	<b>Operation</b>	<b>3-1</b>
	Powering the CAL291 .....	3-1
	Input Signal .....	3-1
	Microphone Placement .....	3-1
	Pressure-Residual Intensity Measurement .....	3-2
	Amplitude/Phase Normalization .....	3-4
<b>Appendix A</b>	<b>Technical Specifications</b>	<b>A-1</b>
	Standards .....	A-1
	Input .....	A-1
	Input Connector .....	A-1
	Acoustical Output .....	A-1
	Mechanical Characteristics .....	A-2
	Length .....	A-2
	Width .....	A-2
	Height .....	A-2
	Weight .....	A-2
	Power .....	A-2
<b>Appendix B</b>	<b>Warranty/Customer Satisfaction</b>	<b>B-7</b>



# *List of Figures*

<b>Introduction .....</b>	<b>1-1</b>
<b>Description .....</b>	<b>2-1</b>
CAL291, General View .....	2-1
Aluminum Block with Microphone Ports .....	2-2
CAL291 End Plate.....	2-3
<b>Operation .....</b>	<b>3-1</b>
Microphones In Place Inside Microphone Ports of CAL291 .....	3-2
<b>Technical Specifications .....</b>	<b>A-1</b>
<b>Warranty/Customer Satisfaction .....</b>	<b>B-7</b>



# *List of Tables*

<b>Introduction</b> .....	<b>1-1</b>
<b>Description</b> .....	<b>2-1</b>
<b>Operation</b> .....	<b>3-1</b>
Output Level and Maximum Input Voltage .....	3-3
<b>Technical Specifications</b> .....	<b>A-1</b>
Output Level and Maximum Input Voltage .....	A-2
<b>Warranty/Customer Satisfaction</b> .....	<b>B-7</b>



# *Introduction*

**The Larson Davis Model CAL291 Residual Intensity Calibrator satisfies the residual intensity test device specifications of both IEC 1043:1993 and ANSI S1.9-1996.**

---

## **About This Manual**

---

This manual has 3 chapters and 1 appendix covering the following topics:

- *Chapter 1 - Introduction:* Orients the user to the contents of this user manual and the features, functions and measurement capabilities of the CAL291. It also includes instructions on unpacking the CAL291.
- *Chapter 2 - Description:* Provides a physical description of the CAL291.
- *Chapter 3 - Operation:* Describes the setup and operation of the CAL291.
- *Appendix A - Specifications:* Presents the technical specifications of the CAL291.

---

## Features

---

The Larson Davis Model CAL291 Residual Intensity Calibrator has the following features:

- Applies the same signal with zero phase difference to a pair of 1/2" or 1/4" microphones
- Can be driven by external signal generators such as the following:
  - Larson Davis Model SRC20 Signal Source
  - Analog or digital signal generator modules available for the Larson Davis Models 2800, 2900, 3000+ and 3200 portable real-time analyzers.
- Built-in amplifier provides sound pressure levels to 122 dB

---

## Applications

---

- Generation of signals for verification of the amplitude/phase accuracy of multi-channel acoustic measurement systems
- Amplitude/Phase Normalization: The digital filters of the Larson Davis analyzers provide both amplitude and phase, permitting the measurement of the complex transfer function between two measurement channels, including microphones, in 1/3 octave frequency bands. By using the CAL291 to excite both microphones simultaneously, the amplitude and phase differences between the two measurement channels can be determined as a function of frequency. From this information, a correction function can be generated within the analyzer to correct for any amplitude and phase errors which may have existed between channels prior to the normalization procedure.

---

## Unpacking and Inspection

---

Your CAL291 has been shipped in protective packaging. Please verify the package contains the items listed below and retain the shipping container for safe shipment at a future date. Report any damage or shortage immediately to Larson Davis, Inc. at 801 375-0177.

If you have not already done so, please record your instrument's serial number (located on the bottom of the instrument) and the purchase date. You may be asked to give this information in future communications with Larson Davis.

---

## Accessories

---

The CAL291 is delivered with the following *standard* accessories:

- PSA004 100 - 240 Vac to 12Vdc 2.5A Switching AC Power Adaptor
- Two ADP038 1/2" to 1/4" microphone adaptors
- User Manual (Larson Davis part number I291.01)
- Calibration Certificate



## Description

The physical description of the CAL291 is presented in this chapter. Operational information is presented in Chapter 3 "Operation" on page 3-1

---

### General Description

---

The CAL291 has a flat shape factor for optimal use on a table or desktop. In use, the sound intensity probe of the intensity measurement system to be evaluated is laid flat on the table with the two microphones inserted into the microphone ports of the CAL291 as shown in FIGURE 2-1.



**FIGURE 2-1 CAL291, General View**

## Microphone Ports

---

The microphone ports are on two opposite faces of an aluminum block mounted on one end of the CAL291, as shown in FIGURE 2-2.

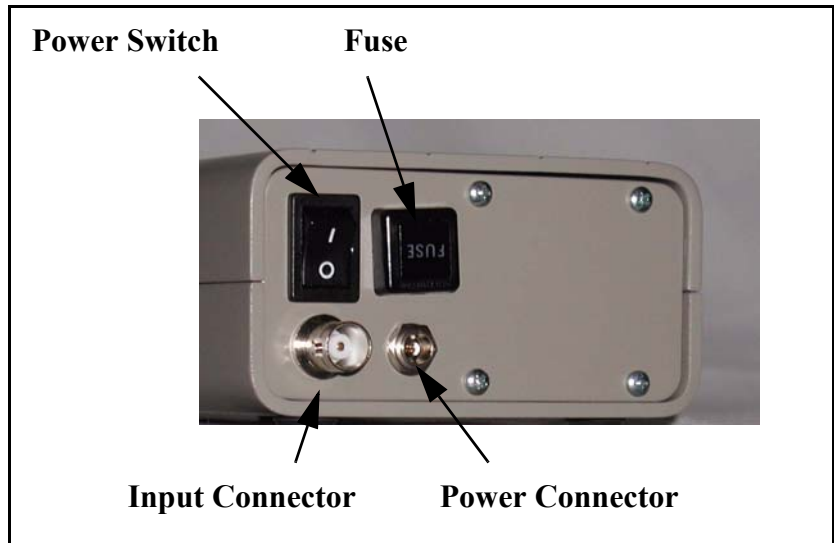

**FIGURE 2-2 Aluminum Block with Microphone Ports**

## End Plate

---

The power switch, electrical input connector, DC power connector and fuse are located on the end plate, as shown in FIGURE 2-3.



**FIGURE 2-3** CAL291 End Plate

## Connectors

---

### Input

BNC Female

### Power

2.5 X 5.5 mm coaxial connector, center positive



# Operation

**This chapter presents a detailed description of the operation of the CAL291.**

---

## Powering the CAL291

---

*An LED in the center of the top surface of the CAL291 is illuminated when the CAL291 power is On.*

The CAL291 is powered by the Larson Davis PSA004, which is supplied as a standard accessory. Connect the AC power cable to mains power and the DC output to the power connector on the end plate of the CAL291. Press the upper portion of the power switch (I position) to switch on the CAL291 and press the lower portion (O) to switch it off.

---

## Input Signal

---

*The CAL291 was designed to work optimally with the analog and digital signal generators available with the Larson Davis Models 2800, 2900, 3000+ and 3200 portable real-time Analyzers.*

Connect the output from an external signal generator capable of generating pink noise to the BNC input on the end plate of the CAL291.

---

## Microphone Placement

---

In most cases this CAL291 will be used with a dual channel sound intensity probe, although it can also be used with two separate microphones mounted on microphone preamplifiers.

- A.** If using a sound intensity probe, separate the two microphones as described in the operating manual for the probe, remove the spacer, and spread the microphones far enough apart that they can be placed over the microphone port block. Do not remove the microphone grid caps. Slide them firmly into the two ports as shown in FIGURE 3-1.



**FIGURE 3-1 Microphones In Place Inside Microphone Ports of CAL291**

- B.** If using separate microphones, insert each firmly into the microphone ports. It may be necessary to place a support beneath the preamplifiers so that they are aligned parallel to the center line of the microphone port openings.

---

## Pressure-Residual Intensity Measurement

---

The CAL291 can be used to determine the pressure-residual intensity index of either the sound intensity probe or the complete sound intensity measurement system.

With the probe microphones inserted into the microphone ports as described in "Microphone Placement" 'on page' 3-2, excite the CAL291 with pink noise at a low voltage level using the signal generator.

Table 3-1 shows the recommended maximum input voltage level to the CAL291 for several different frequency bands, and the corresponding sound pressure levels which would be produced at the microphone diaphragms.

To maintain the total harmonic distortion less than 1%, the sound pressure level at the microphones should be kept within the range 25 dB - 115 dB (1 kHz). Adjust the signal generator output to obtain a sound pressure level at the microphones within this range and the amplitude level difference between the two microphones will be < 0.1 dB (@ 1kHz). The phase angle between the acoustic signals will be zero.

Frequency, Hz	Output SPL, dB re. 20 $\mu$ Pa	Maximum Input Voltage, dB $\mu$ V
250	$\geq 122$	120.0
1 k	$\geq 115$	122.8
2.5 k	$\geq 105$	125.5
6.3 k	$\geq 90$	109.5

**Table 3-1 Output Level and Maximum Input Voltage**

The signals applied to the microphones will now be as required for the measurement of the pressure-residual intensity index.

ANSI S1.9-1997 and IEC 1043:1993 call for the measurement of the pressure-residual intensity index in 1/3 octave bands (1/1 octave bands for instruments providing only 1/1 octave analysis). The user is directed to refer to the appropriate standards for further details on performing these measurements as specified.

---

## Amplitude/Phase Normalization

---

For sound intensity measurements, it is essential to have the best possible amplitude and phase match between measurement channels in order to meet the minimum pressure-residual intensity index values stipulated by the standards. Both the ANSI and IEC standards include provisions for phase compensation in the measurement system.

Because a residual intensity testing device is being used as the acoustic source for both microphones, we know that they are exposed to equal amplitude signals with zero phase difference between them (within the limits of the device). Thus, any variation of the magnitude of the transfer function between channels from unity (0 dB) and of the phase from zero is the result of errors in the measurement system which includes the microphones, intensity probe electronics and the analyzer.

Some instruments, such as the Larson Davis Models 2900B, 3000+ and 3200 can not only measure the complex transfer function between channels in 1/3 octave frequency bands, but they can also use the measured transfer function to generate a correction function to correct for some of the errors and decrease the pressure-residual intensity index of the system. For further details on the implementation of this normalization technique, see the operators manual for the instrument being used.

# A

## *Technical Specifications*

The technical specifications in this chapter are subject to change without notice. Please refer to calibration and test results for data on a specific unit.

### **Standards**

---

Meets the residual intensity test device specifications as presented in IEC 1043:1993 “Instruments for the measurement of sound intensity” and ANSI S1.9-1996 “Instruments for measurement of sound intensity”.

### **Input**

---

#### **Input Connector**

BNC with impedance 1 M $\Omega$

### **Acoustical Output**

---

- Sound Pressure Level (1% harmonic distortion): 25 - 115 dB @ 1 kHz
- SPL difference between channels: < 0.1 dB @ 1 kHz
- Maximum pressure-intensity index: > 27 dB
- Output Level and Maximum Input Voltage for < 1% distortion: as specified in Table A-1 ” on page A-2.

Frequency, Hz	Output SPL, dB re. 20 $\mu$ Pa	Maximum Input Voltage, dB $\mu$ V
250	$\geq 122$	120.0
1 k	$\geq 115$	122.8
2.5 k	$\geq 105$	125.5
6.3 k	$\geq 90$	109.5

**Table A-1 Output Level and Maximum Input Voltage**

## Mechanical Characteristics

---

### Length

25.6 cm (10.3 in)

### Width

10.0 cm (4.0 in)

### Height

5.3 cm (1.1 in)

### Weight

1.0 kg (2.2 lb.)

## Power

---

D.C. Power: 9 - 16 Vdc, 400 mA provided by PSA004 DC Power Supply (included) 90 - 240 Vac @ 50 - 60 Hz

# B

## *Warranty/Customer Satisfaction*

**A. Total Customer Satisfaction.** Larson Davis, Inc. ("LD") guarantees Total Customer Satisfaction. If, at any time you are not completely satisfied with any LD product, LD will repair, replace or exchange it at no charge, except as otherwise provided in this Limited Warranty. The employees of LD strive to provide superior, unmatched customer service. Should you find yourself dissatisfied with any LD product for any reason, consult a LD Application engineer or local representative/ distributor to discuss your situation.

**B. Purchase Price Refund/Limited Warranty.** LD warrants to the original purchaser (the "Buyer") that, unless otherwise expressly specified in writing by a LD officer, all LD products shall be free of defects in material and workmanship for a period of two (2) years from date of original purchase. In furtherance of LD's commitment to Total Customer Satisfaction, LD will, for a period of one (1) year from date of original purchase, refund 100% of the customer's purchase price for any LD product with which the buyer is not completely satisfied, subject to the exceptions contained in Paragraph J of this Limited Warranty. The option of a refund may be selected during this one (1) year period in lieu of repair, replacement or exchange of the product.

**Extended Labor Warranty.** In furtherance of LD's commitment to Total Customer Satisfaction, LD offers an extended labor warranty of one (1) year on all products calibrated or certified by a factory technician at any time or from time-to-time during the first seven years of the product life from date of manufacture. The customer's sole remedy pursuant to this extended warranty is to receive free labor for any repairs required during the period in which the extended warranty is effective. This extended labor warranty is subject to the limitations as outlined in Paragraph J.

**Service & Repair Limited Warranty.** In addition to the limited warranties set forth above, LD offers a 90-day parts and labor limited warranty for all repair work performed at the factory. This warranty is limited to parts repaired or replaced at the factory by LD. This warranty is also subject to the limitations as outlined in Paragraph J.

**C. Shipping Charges.** The buyer will return the product freight prepaid by the Buyer to an authorized service center. The product will be returned to the buyer freight prepaid by LD.

**D. Products Manufactured by Others.** This Limited Warranty does not cover any products manufactured by others. Such products are subject to the warranty, if any, of their respective manufacturers, and to be repaired only by a respective authorized service person for such products. LD shall have no obligation to undertake repairs of products manufactured by others.

**E. NO SPECIAL, INCIDENTAL OR CONSEQUENTIAL DAMAGES. LD'S SOLE OBLIGATIONS UNDER THIS LIMITED WARRANTY ARE SET FORTH ABOVE IN PARAGRAPHS A, B, C AND D. IN NO EVENT SHALL LD (ITS CONTRACTORS OR SUPPLIERS) BE LIABLE TO THE BUYER FOR ANY LOST PROFITS, DIRECT, INDIRECT, SPECIAL, INCIDENTAL OR CONSEQUENTIAL DAMAGES, WHETHER BASED ON CONTRACT, IN TORT OR ANY OTHER LEGAL THEORY. SUCH DAMAGES FOR WHICH LD SHALL NOT BE RESPONSIBLE INCLUDE, BUT ARE NOT LIMITED TO, LOST TIME AND CONVENIENCE, LOSS OF USE OF THE PRODUCT, THE COST OF A PRODUCT RENTAL, COSTS OF GASOLINE, TELEPHONE, TRAVEL OR LODGING, THE LOSS OF PERSONAL OR COMMERCIAL PROPERTY, AND THE LOSS OF REVENUE.**

Some states do not permit the limitation or disclaimer of incidental or consequential damages. Therefore, the above disclaimer of incidental or consequential damages may not apply to certain purchasers.

**F. NO LIABILITY IN EXCESS OF PURCHASE PRICE. IN NO EVENT SHALL LD'S OBLIGATIONS UNDER THIS LIMITED WARRANTY EXCEED THE PURCHASE PRICE OF THE PRODUCT PLUS ANY SHIPPING CHARGES THAT LD MAY BE OBLIGATED TO PAY PURSUANT TO PARAGRAPH C ABOVE.**

**G. NO EXTENSION OF STATUTE OF LIMITATIONS. ANY REPAIRS PERFORMED UNDER THIS LIMITED WARRANTY SHALL NOT IN ANY WAY EXTEND THE STATUTES OF LIMITATIONS FOR CLAIMS UNDER THIS LIMITED WARRANTY.**

**H. WAIVER OF OTHER WARRANTIES. THE EXPRESS WARRANTIES SET FORTH IN THIS LIMITED WARRANTY ARE IN LIEU OF AND EXCLUDE ANY AND ALL OTHER WARRANTIES, EXPRESSED OR IMPLIED, INCLUDING BUT NOT LIMITED TO, THE IMPLIED WARRANTIES OF MERCHANTABILITY AND FITNESS FOR A PARTICULAR PURPOSE.**

Some states do not permit the disclaimer of implied warranties. Therefore, the above disclaimer of implied warranties may not apply to certain purchasers.

**I. Procedure for Warranty Performance. If the product fails to perform to LD's specifications, the Buyer must provide LD with the applicable model and serial numbers, the date of purchase, and the nature of the problem.**

**J. ADDITIONAL EXCLUSIONS FROM THIS LIMITED WARRANTY. NOTWITHSTANDING ANYTHING TO THE CONTRARY CONTAINED IN THIS LIMITED WARRANTY, THIS LIMITED WARRANTY DOES NOT COVER ANY OF THE FOLLOWING:**

**1.EQUIPMENT THAT HAS BEEN ABUSED, DAMAGED, USED BEYOND RATED CAPACITY, OR REPAIRED BY PERSONS OTHER THAN AUTHORIZED SERVICE PERSONNEL.**

**2.DAMAGE CAUSED BY ACTS OF GOD THAT INCLUDE, BUT ARE NOT LIMITED TO, HAILSTORMS, WINDSTORMS, HURRICANES, TORNADOES, SANDSTORMS, LIGHTNING, FLOODS AND EARTHQUAKES.**

**3.DAMAGE UNDER CONDITIONS CAUSED BY FIRE OR ACCIDENT, BY ABUSE OR BY NEGLIGENCE OF THE USER OR ANY OTHER PERSON OTHER THAN LD, BY IMPROPER INSTALLATION, BY MISUSE, BY INCORRECT OPERATION, BY “NORMAL WEAR AND TEAR”, BY IMPROPER ADJUSTMENT OR ALTERATION, BY ALTERATIONS NOT COMPLETED BY AUTHORIZED SERVICE PERSONNEL, OR BY FAILURE OF PRODUCTS PARTS FROM SUCH ALTERATIONS.**

**4.COSTS OF REPAIRING DAMAGE CAUSED BY POOR OR IMPROPER MAINTENANCE OR UNAUTHORIZED REPAIR.**

**5.COSTS OF MODIFYING THE PRODUCT IN ANY WAY ONCE DELIVERED TO THE BUYER, EVEN IF SUCH MODIFICATIONS WERE ADDED AS A PRODUCTION CHANGE ON OTHER PRODUCTS MADE AFTER THE BUYER'S PRODUCT WAS BUILT.**

**Authority to Alter This Limited Warranty.** No agent, representative, distributor, or authorized dealer of LD has any authority to alter the terms of this Limited Warranty in any way. This Limited Warranty may be altered only in a writing signed by an authorized officer of LD.



# *Index*

## **A**

<b>About</b> .....	1-1
<b>Accessories</b> .....	1-3
<b>Amplitude/Phase Normalization</b> .....	3-4
<b>Applications</b> .....	1-2

## **C**

### **Connectors**

DC Power .....	2-3
Input .....	2-3

## **D**

<b>Description</b> .....	2-1
General .....	2-1
<b>Dimensions</b> .....	A-2

## **F**

<b>Features of CAL291</b> .....	1-2
<b>Fuse</b> .....	2-3

## **I**

<b>Input Signal</b> .....	3-1
<b>Inspection</b> .....	1-3
<b>Introduction</b> .....	1-1

## **L**

<b>Larson Davis 2900B</b> .....	3-4
<b>Larson Davis 3000+</b> .....	3-4
<b>Larson Davis 3200</b> .....	3-4

## **M**

<b>Maximum Output Sound Pressure Level</b> .....	A-1
--	-----

<b>Mechanical Characteristics</b> .....	A-2
<b>Microphone Placement</b> .....	3-1
<b>Microphone Ports</b> .....	2-2

## **N**

### **Normalization**

Amplitude/Phase .....	3-4
-----------------------	-----

## **O**

### **Output**

Acoustical .....	A-1
Amplitude Difference .....	A-1
Maximum Input Voltage .....	A-1
Sound Pressure Level .....	A-1

## **P**

<b>Power</b> .....	3-1, A-2
<b>Power Switch</b> .....	2-3
<b>Pressure-Residual Intensity Measurement</b> .....	3-2

## **S**

<b>Standards Met</b> .....	A-1
----------------------------	-----

## **T**

<b>Technical Specifications</b> .....	A-1
---------------------------------------	-----

## **U**

<b>Unpacking</b> .....	1-3
------------------------	-----

## **W**

<b>Warranty</b> .....	B-7
<b>Weight</b> .....	A-2