



MODEL REF2510R BY WILCOXON

VIBRATION REFERENCE SOURCE

HANDHELD VIBRATION SHAKER KIT

- Quickly and easily verify sensor operation and cable integrity in the field
- User-selectable operating frequency and measurement type (peak or RMS)
- Crossover frequencies for easy velocity verification
- Selections retained after powering off
- Rugged boot offers protection in harsh industrial environments
- Up to 40 hours of battery life
- Manufactured in an approved ISO 9001 facility Full control and live monitoring via LD Atlas app

TYPICAL APPLICATIONS

- Validate human vibration meter measurements
- Verify vibration sensor performance
- Test cable integrity, signal conditioning, DAQ, and alert/alarm levels in the field

The ReferenceMate portable reference source enables users in the field to easily verify sensor performance and the integrity of the cabling between the sensor and the online system. A built-in reference accelerometer assures that a 1 g test level is maintained for sensors weighing up to 250 grams. Frequency of operation (61.4 Hz for imperial measurements, 100 Hz to confirm sensor calibration value, and 159.2 Hz for metric measurements) and measurement type (peak/RMS) are push button selected. The REF2510R kit includes all the accessories needed for simple vibration data collection. Handheld Vibration Shaker Model REF2500 is also available standalone without the full accessory kit.

LEDs notify the user when battery condition falls below operational levels or if the unit is overloaded. For calibration verification, reference test points are provided to verify the output of the internal sensor.



REF2500

SPECIFICATIONS

Performance			
Operating frequency ^[1] , ± 1.5%	61.4 Hz	100.0 Hz	159.2 Hz
Acceleration output ^[2] , ± 3%	1.0 g (9.81 m/s ²)	1.0 g (9.81 m/s ²)	1.0 g (9.81 m/s ²)
Velocity output ^[2]	1.0 ips (25.4 mm/s)	0.61 ips (15.6 mm/s)	0.39 ips (9.8 mm/s)
Displacement output ^[2]	2.6 mils (65.9 μm)	0.98 mils (24.8 μm)	0.39 mils (9.8 μm)
Operating cycles, 250 gram load ^[3]	1,280	320	240

Physical	
Shaker dimensions	Diameter: 2.59 in. (6.6 cm) Height: 10.33 in. (26.2 cm)
Weight, with batteries	900 grams (32 oz)
Case material	6061 aluminum, black hard-coated anodized
Boot material	thermoplastic rubber
Mounting thread	1/4-28 female
Mounting torque, max	10 in-lb (112 N-cm)
Distortion, 100-250 gram load	≤ 7%
Load, min to max	none to 8.8 oz (250 grams)
Automatic switch off time	approx. 90 ± 10 sec defeatable
IP rating	IP54
Ramp-up time	≤ 3 sec

Temperature Range	
Operating	-10° to +55°C (+15° to +130°F)
Storage	-40° to +85°C (-40° to +185°F)

Power	
Internal battery	4x AA alkaline batteries
DC power	6 VDC ± 5%, 1A, center positive

REF2510R Included Items	
REF2500 Handheld Shaker	
Protective Boot	
4x AA batteries	
Calibration sheet	
Belt clip	
Wrench	
Carrying case with foam insert	
1/4-28 to 1/4-28 SF6 mounting stud	
9155-MNT06 - 10-32 Female to 1/4-28 Male Adapter Plate	
REF2500 Included Items	
REF2500 Handheld Shaker	
9155-MNT06 - 10-32 Female to 1/4-28 Male Adapter Plate	

- [1] User-selectable.
 [2] Peak or RMS.
 [3] Using supplied alkaline batteries.

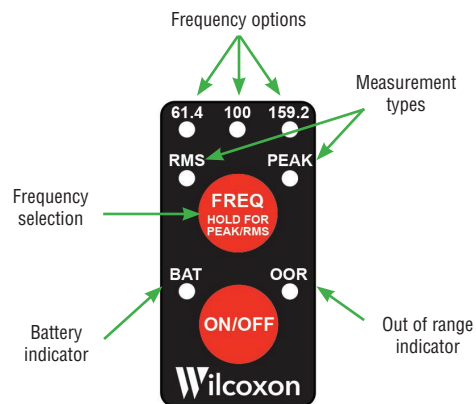

Front Panel Controls

to make selections at the push of a button

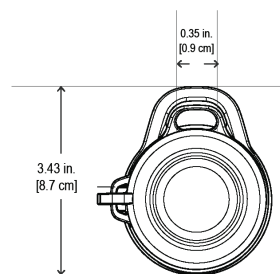

Top View

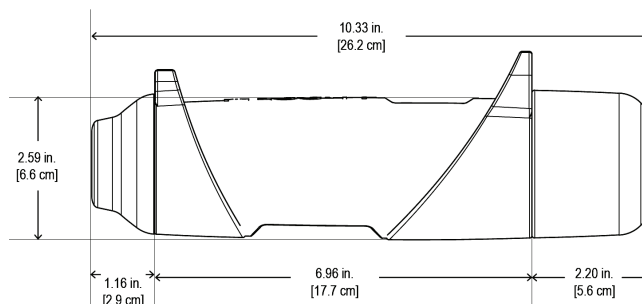

Side View



3425 Walden Avenue, Depew, NY 14043 USA

larsondavis.com | sales@larsondavis.com | 888 258 3222 | +1 716 926 8243